

F.lli TASSALINI S.p.A.

Fact Sheet

Lower Level Gauge

CODE K38

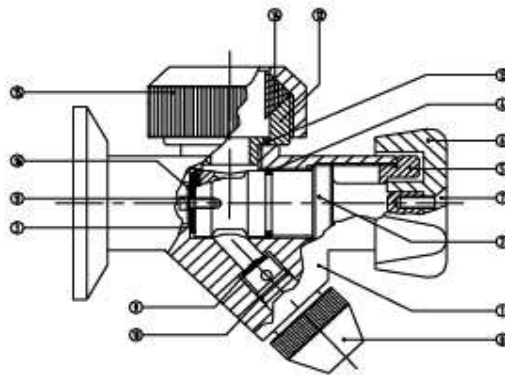

1. Plug casing
2. Plug
3. Plug seal
4. OR seal ring
5. Locking collar
6. Handle
7. Screw
8. Sampling nozzle
9. Drain seal
10. OR seal ring
11. Screw
12. Glass holder
13. OR seal ring
14. Glass seal
15. Glass locking collar
16. Washer

Pos.	Qty	Part No.	Description	Material
1	1	K38.01	Plug casing	AISI 316L
2	1	38/48.02	Plug	AISI 316L
3	1	38/48.03	Plug seal	NBR
4	1	OR 3050	OR seal ring	NBR
5	1	38/48.05	Locking collar	ABS
6	1	38/48.06	Handle	ABS
7	1	TS M4 x 10	Screw	AISI 304
8	1	38.08	Sampling nozzle	AISI 316L
9	1	38.09	Drain seal	NBR
10	1	OR 2043	OR seal ring	NBR
11	1	TCCE M3 x 6	Screw	AISI 304
12	1	38/47.12	Glass holder	AISI 316L
13	1	OR 2068	OR seal ring	NBR
14	1	38/47.14	Glass seal	SILICONE/VITON
15	1	38/47.15	Glass locking collar	ABS/AISI 304
16	1	38/48.16	Washer	AISI 304

F.Iii TASSALINI S.p.A. Fact Sheet

Upper Level Gauge

triclover connection

CODE K47

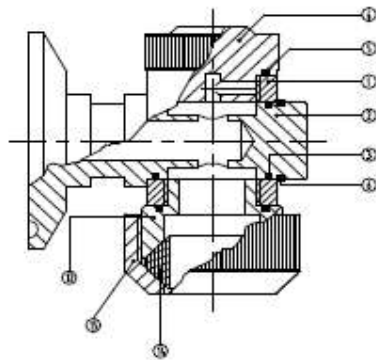

- 1. Upper level gauge
- 2. Upper level plug
- 3. OR seal ring
- 4. Air vent plug
- 5. OR seal ring
- 6. Seeger
- 12. Glass holder
- 14. Glass seal
- 15. Glass locking collar

Pos.	Qty	Part No.	Description	Material
1	1	47.01	Upper level gauge	AISI 316L
2	1	K47.02	Upper level plug	AISI 316L
3	2	OR 2056	OR seal ring	NBR
4	1	47/48.04	Air vent plug	AISI 316L
5	2	OR 2068	OR seal ring	NBR
6	1	SEE A18 411	Seeger	AISI 304
12	1	38/47.12	Glass holder	AISI 316L
14	1	38/47.14	Glass seal	SILICONE/VITON
15	1	38/47.15	Glass locking collar	ABS/AISI 304

Pos 4. M16x1mm